

ARV VAULT

TOP VIEW

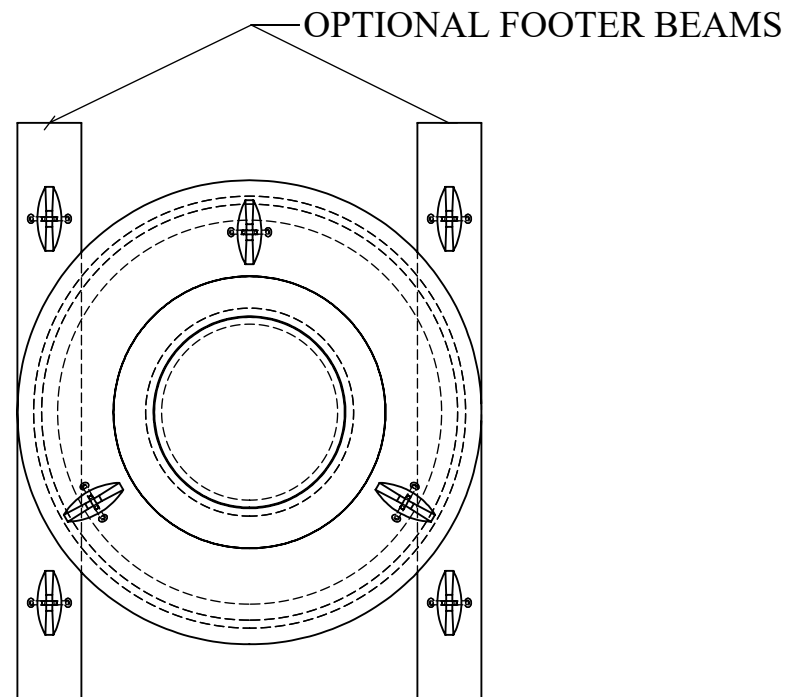

END VIEW

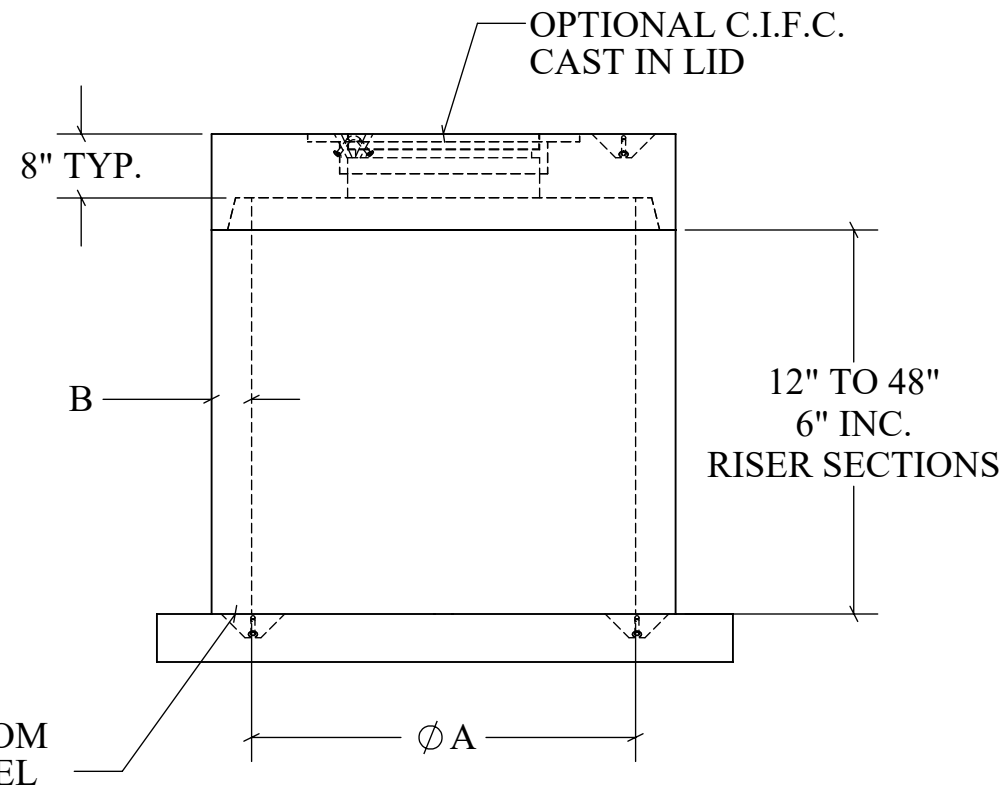

SECTION VIEW

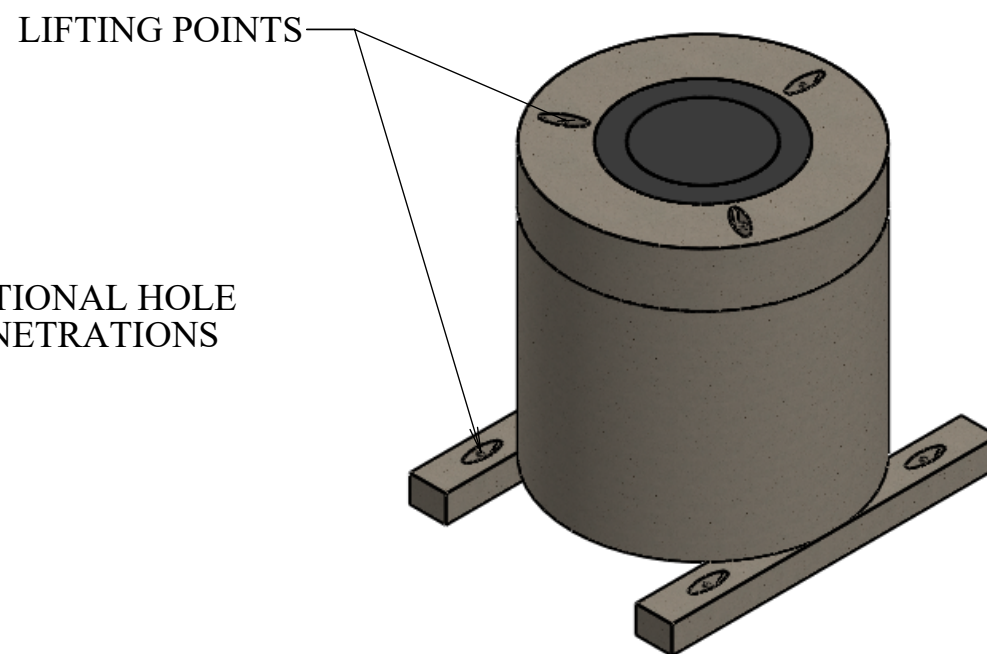
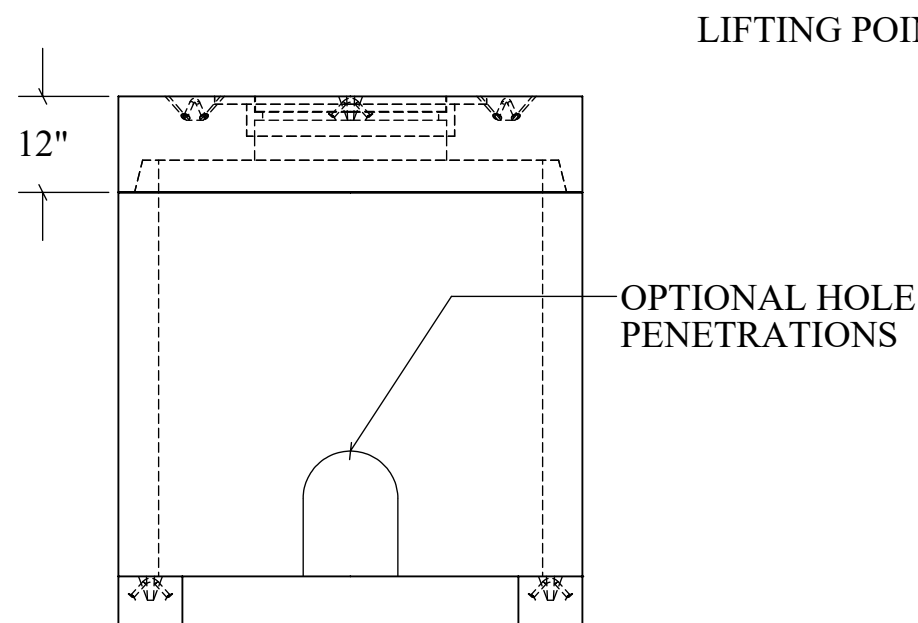

RISER DIMENSIONS

ϕA	B	LBS. / VF
48"	5"	1,000
72"	7"	1,700
96"	9"	3,080

FLAT TOP LID DIMENSIONS

MANHOLE I.D.	WEIGHT (LBS.)
48"	1,820
72"	4,200
96"	7,430

STRUCTURAL NOTES:

1. ALL CONCRETE SHALL BE PLACED IN A SINGLE CONTINUOUS OPERATION (MONOLITHIC POUR).
2. CONCRETE SHALL HAVE A MINIMUM 28-DAY COMPRESSIVE STRENGTH OF 4000 PSI CONCRETE AGGREGATE SHALL CONFORM TO ASTM C33.
3. CEMENT SHALL CONFORM TO ASTM C150, TYPE I, II, OR III.
4. ALL MANHOLE CONSTRUCTION SHALL CONFORM TO ASTM C478.
5. H-20 LOAD RATED

DRAWN:
6/23/23

WEIGHT:
VARIES

SCALE:
VARIES

MATERIAL:
4,000 PSI
CONCRETE

FINISH:
FORM FINISH

DIMENSIONS ARE IN
FEET & INCHES
TOLERANCES: \pm 4-IN.



PRECISION PRECAST

575-382-0501

SALES@PRECISIONPRECAST.CO

WWW.PRECISIONPRECAST.CO

PROPRIETARY AND CONFIDENTIAL THE INFORMATION CONTAINED IN THIS DRAWING IS THE SOLE PROPERTY OF LECO INDUSTRIES INC DBA PRECISION PRECAST. ANY REPRODUCTION PART OR AS A WHOLE WITHOUT WRITTEN PERMISSION OF LECO INDUSTRIES, INC DBA PRECISION PRECAST IS PROHIBITED.