

LANDSCAPE BLOCK 2' - DEEP

TOP VIEW

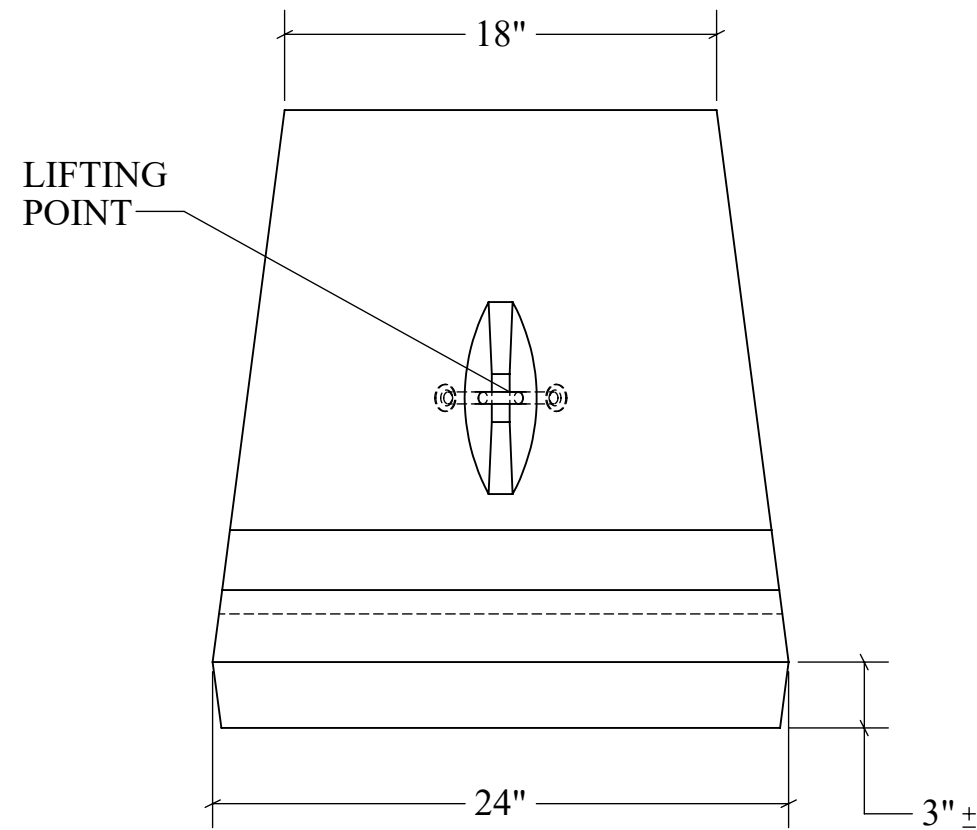

SECTION VIEW

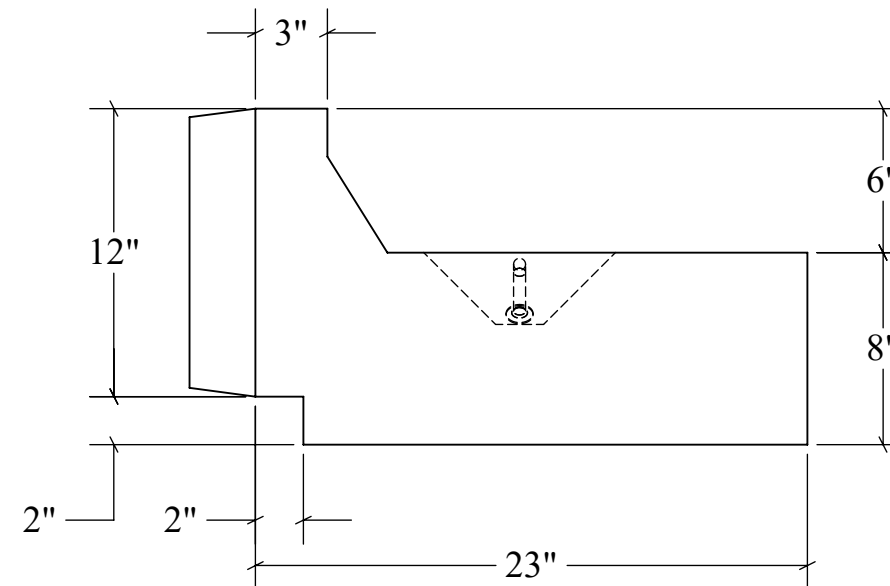

END VIEW

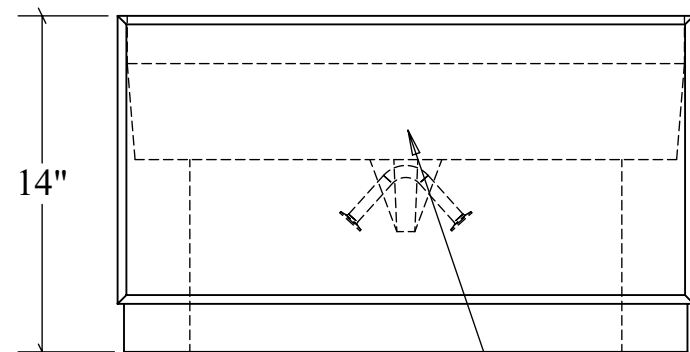

SEE NOTES FOR FINISH

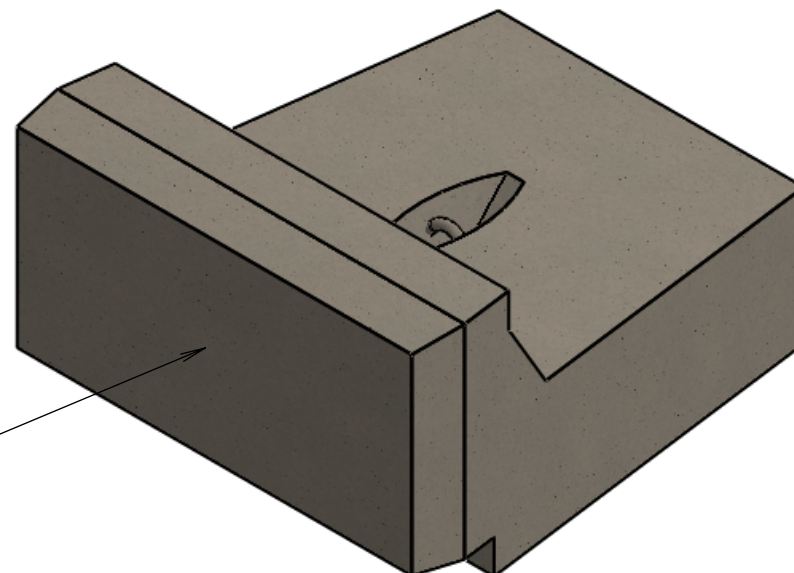

GENERAL NOTES:

1. ALL CONCRETE SHALL BE PLACED IN A SINGLE CONTINUOUS OPERATION (MONOLITHIC POUR).
2. CONCRETE SHALL HAVE A MINIMUM 28-DAY COMPRESSIVE STRENGTH OF 4000 PSI CONCRETE AGGREGATE SHALL CONFORM TO ASTM C33.
3. CEMENT SHALL CONFORM TO ASTM C150, TYPE I, II, OR III.
4. NON-REINFORCED CONCRETE.

QUARRY STONE FACE
SAMPLE FINISH

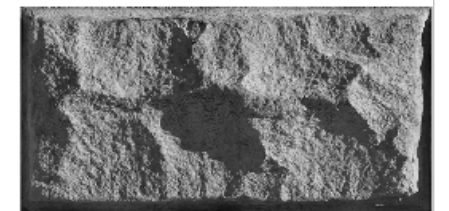

DRAWN: 08/11/21	WEIGHT: 440 LBS.	SCALE: VARIES
MATERIAL: 4,000 PSI CONCRETE	FINISH: FORM FINISH	DIMENSIONS ARE IN FEET & INCHES TOLERANCES: ± 4-IN.



PRECISION PRECAST
575-382-0501
SALES@PRECISIONPRECAST.CO
WWW.PRECISIONPRECAST.CO

PROPRIETARY AND CONFIDENTIAL THE INFORMATION CONTAINED IN THIS DRAWING IS THE SOLE PROPERTY OF LECO INDUSTRIES INC DBA PRECISION PRECAST. ANY REPRODUCTION PART OR AS A WHOLE WITHOUT WRITTEN PERMISSION OF LECO INDUSTRIES, INC DBA PRECISION PRECAST IS PROHIBITED.