

# PAD "PMH/PME", "PME", "PMH"

**TOP VIEW**

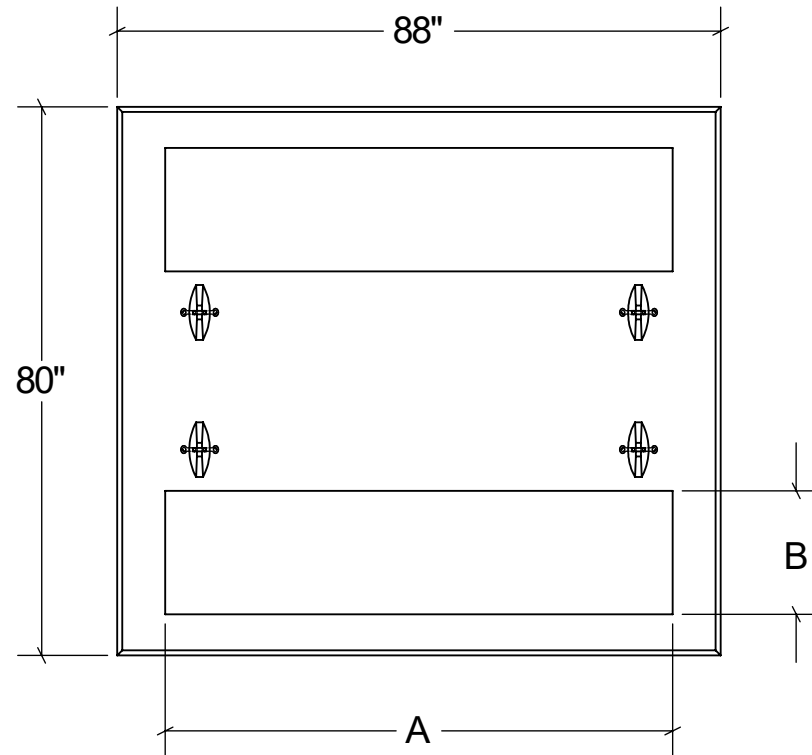

**END VIEW**

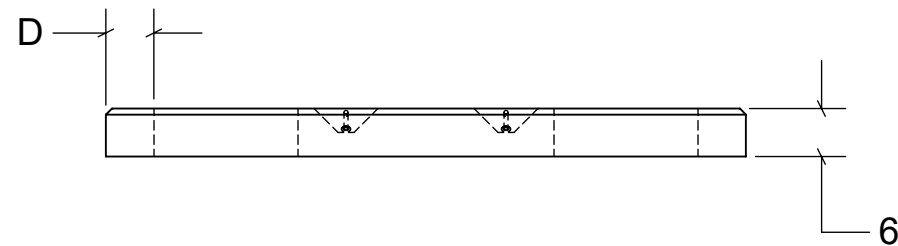

**SECTION VIEW**

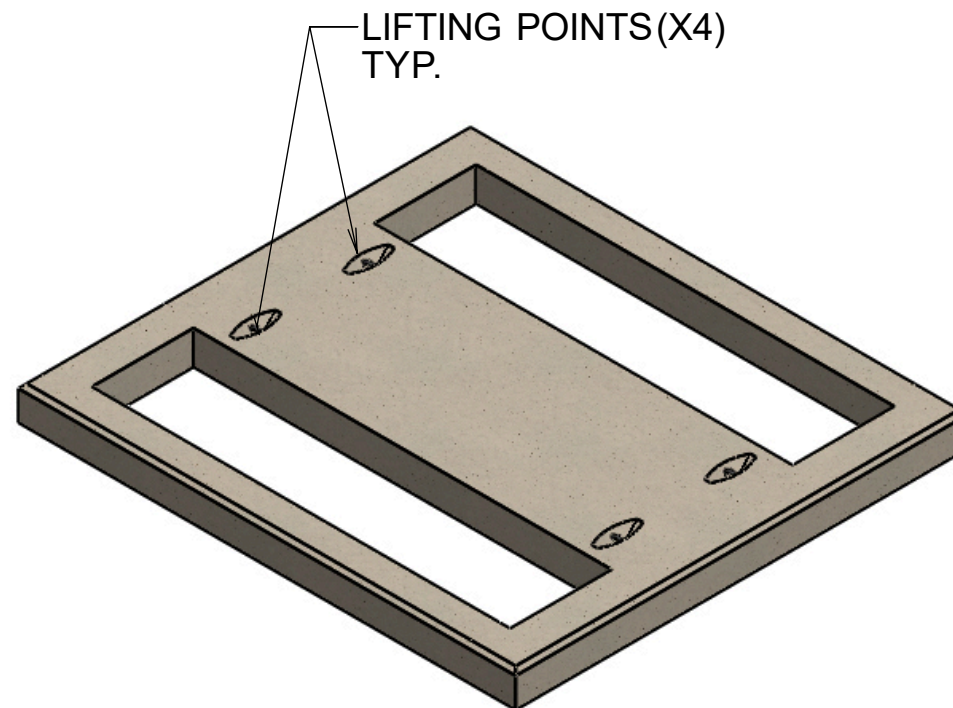

**PAD DIMENSIONS**

NAME	A	B	C	D
PMH/PME	74"	18"	7"	6"
PME	65"	16"	11.5"	10"
PMH	57"	16"	15.5"	10"

**STRUCTURAL NOTES:**

1. ALL CONCRETESHALL BE PLACED IN A SINGLE CONTINUOUS OPERATION (MONOLITHIC POUR).
2. CONCRETESHALL HAVE A MINIMUM 28-DAY COMPRESSIVE STRENGTH OF 4000 PSI CONCRETE AGGREGATE SHALL CONFORM TO ASTM C33.
3. CEMENT SHALL CONFORM TO ASTM C150, TYPE I, II, OR III.
4. MINIMUM REINFORCEMENT GRADE 60 # 5 REBAR 6" O.C. BOTH WAYS, TERMINATE WITH 90° A.C.I. BENDS. 1 1/2" COVER REQD. ON ALL STEEL, DOUBLE MAT

**DRAWN:**  
03/06/23

**WEIGHT:**  
2,265 LBS

**SCALE:**  
VARIES

**MATERIAL:**  
4,000 PSI  
CONCRETE

**FINISH:**  
FORM FINISH

DIMENSIONS ARE IN  
FEET & INCHES  
TOLERANCES: ± 4-IN.

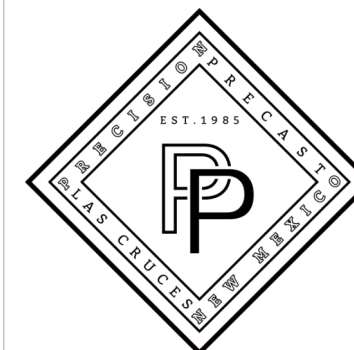

**PRECISION PRECAST**  
575-382-0501  
SALES@PRECISIONPRECAST.CO  
WWW.PRECISIONPRECAST.CO

PROPRIETARY AND CONFIDENTIAL THE INFORMATION CONTAINED IN THIS DRAWING IS THE SOLE PROPERTY OF LECO INDUSTRIES INC DBA PRECISION PRECAST. ANY REPRODUCTION PART OR AS A WHOLE WITHOUT WRITTEN PERMISSION OF LECO INDUSTRIES, INC DBA PRECISION PRECAST IS PROHIBITED.