

# LANDSCAPE BLOCK 6' - STANDARD

**TOP VIEW**

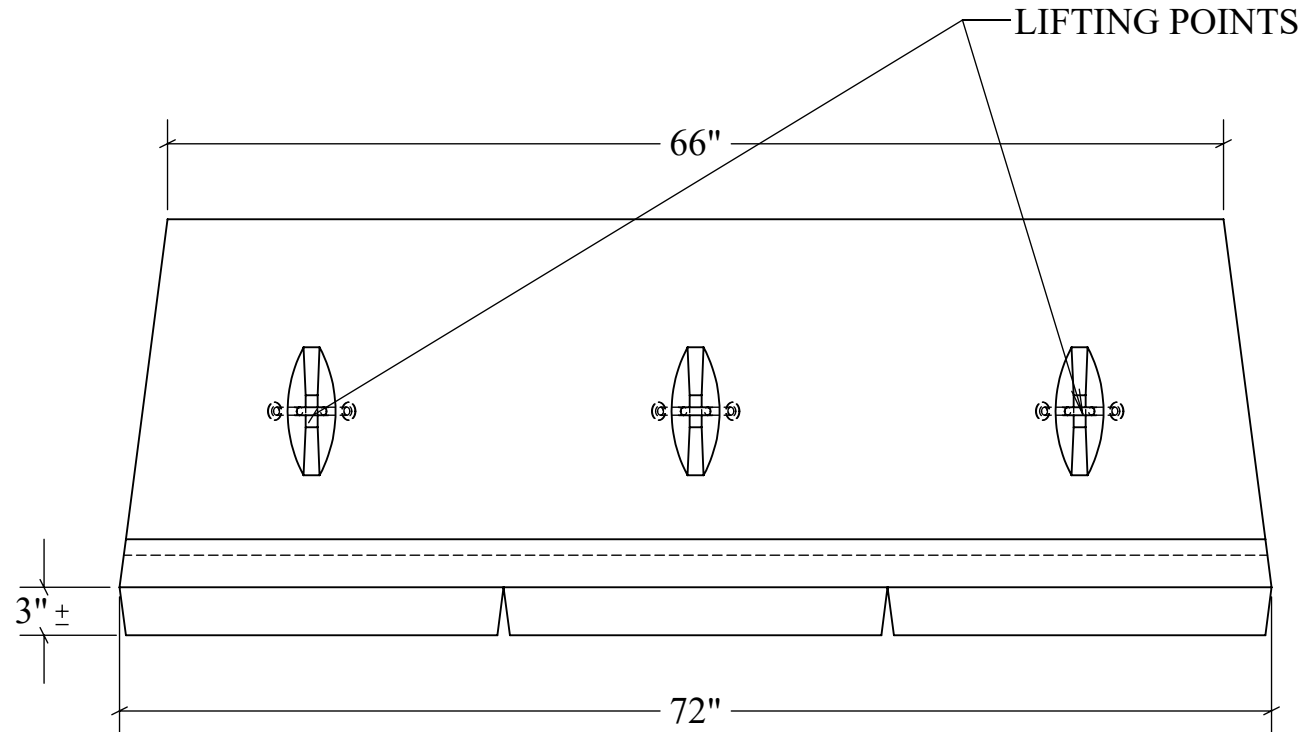

**SECTION VIEW**

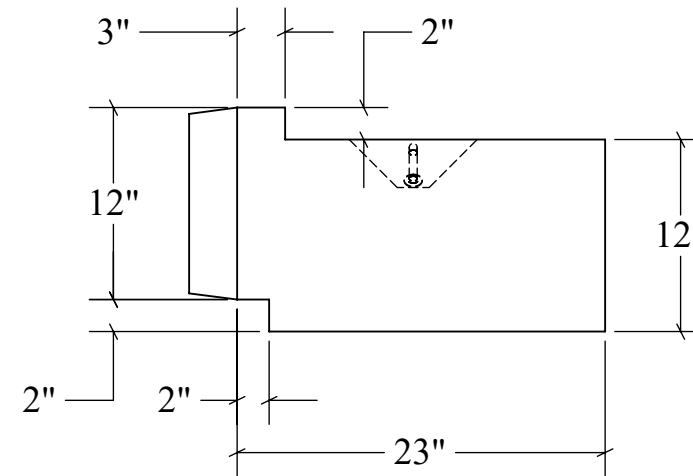

**END VIEW**

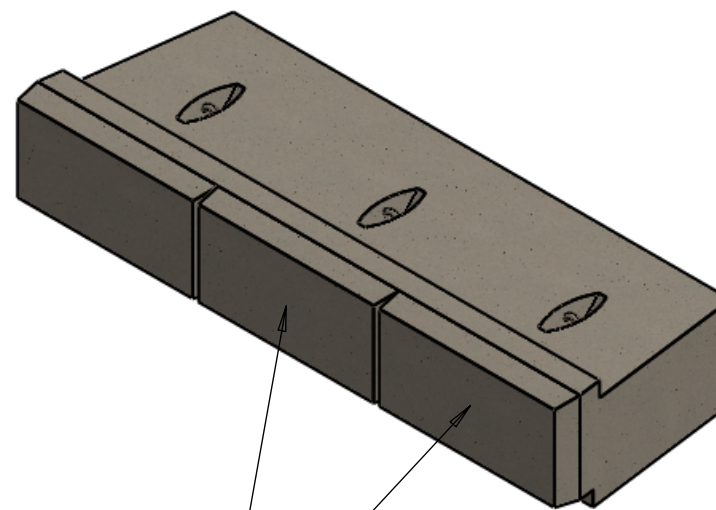
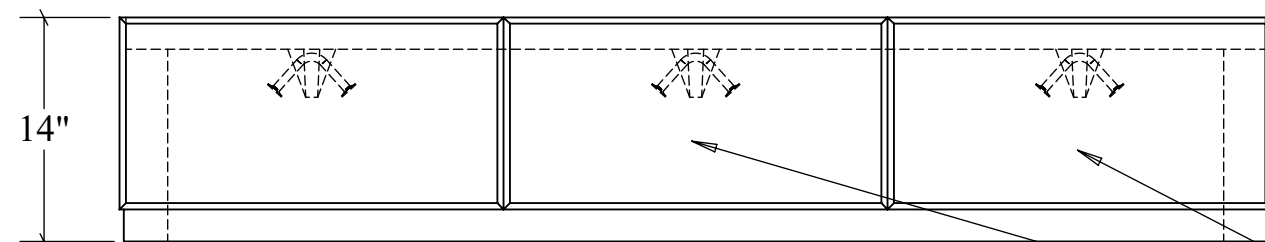

SEE NOTES FOR FINISH

**STRUCTURAL NOTES:**

1. ALL CONCRETE SHALL BE PLACED IN A SINGLE CONTINUOUS OPERATION (MONOLITHIC POUR).
2. CONCRETE SHALL HAVE A MINIMUM 28-DAY COMPRESSIVE STRENGTH OF 4000 PSI CONCRETE AGGREGATE SHALL CONFORM TO ASTM C33.
3. CEMENT SHALL CONFORM TO ASTM C150, TYPE I, II, OR III.
4. NON-REINFORCED CONCRETE.

QUARRY STONE FACE SAMPLE FINISH

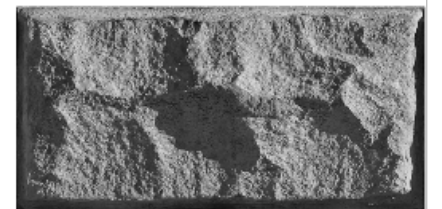

<b>DRAWN:</b> 08/11/21	<b>WEIGHT:</b> 1,880 LBS.	<b>SCALE:</b> VARIES
<b>MATERIAL:</b> 4,000 PSI CONCRETE	<b>FINISH:</b> FORM FINISH	DIMENSIONS ARE IN FEET & INCHES TOLERANCES: ± 4-IN.



**PRECISION PRECAST**  
575-382-0501  
SALES@PRECISIONPRECAST.CO  
WWW.PRECISIONPRECAST.CO

PROPRIETARY AND CONFIDENTIAL THE INFORMATION CONTAINED IN THIS DRAWING IS THE SOLE PROPERTY OF LECO INDUSTRIES INC DBA PRECISION PRECAST. ANY REPRODUCTION PART OR AS A WHOLE WITHOUT WRITTEN PERMISSION OF LECO INDUSTRIES, INC DBA PRECISION PRECAST IS PROHIBITED.