

2500 & 3200 GAL 3 BAFFLE SOI

TOP VIEW

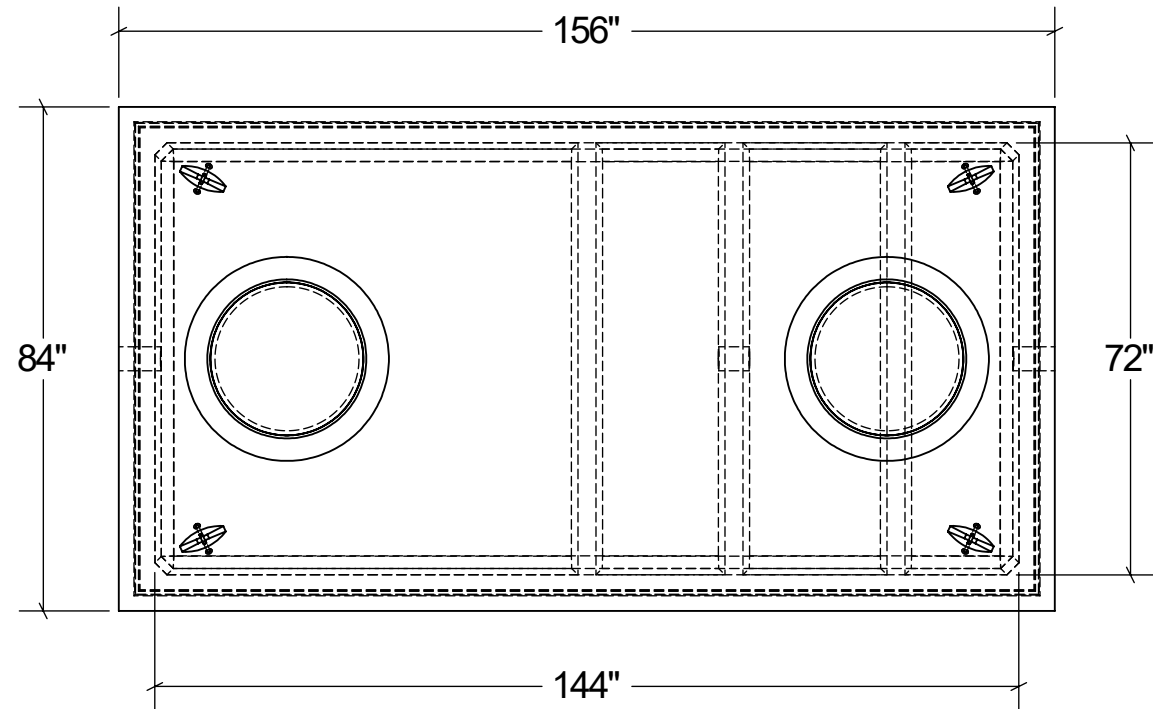

END VIEW

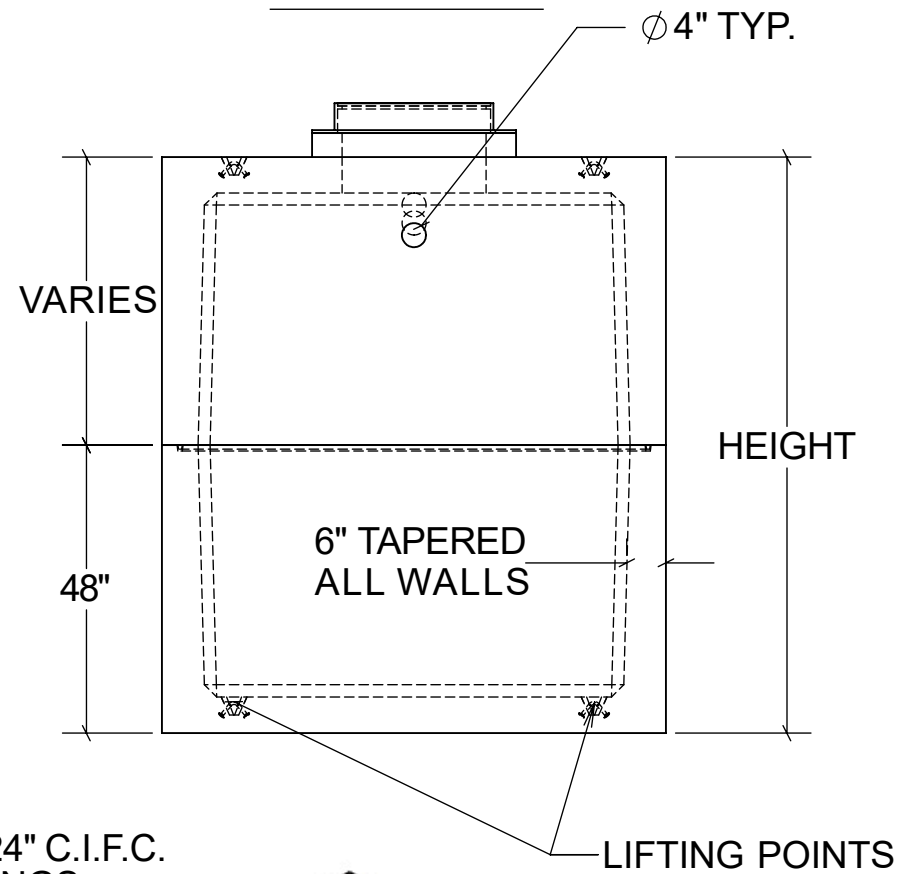

SECTION VIEW

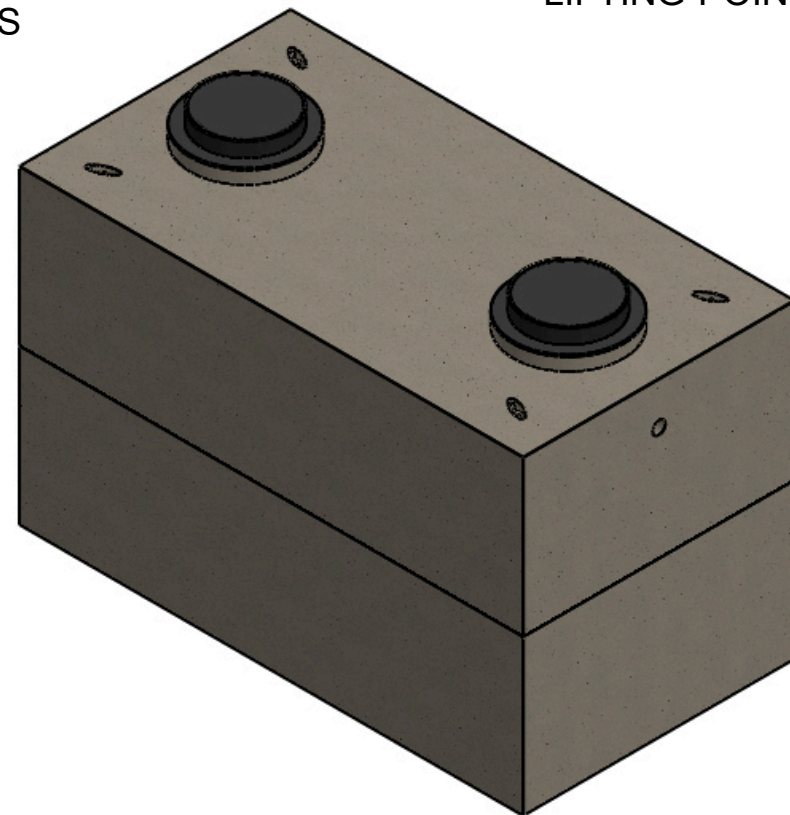
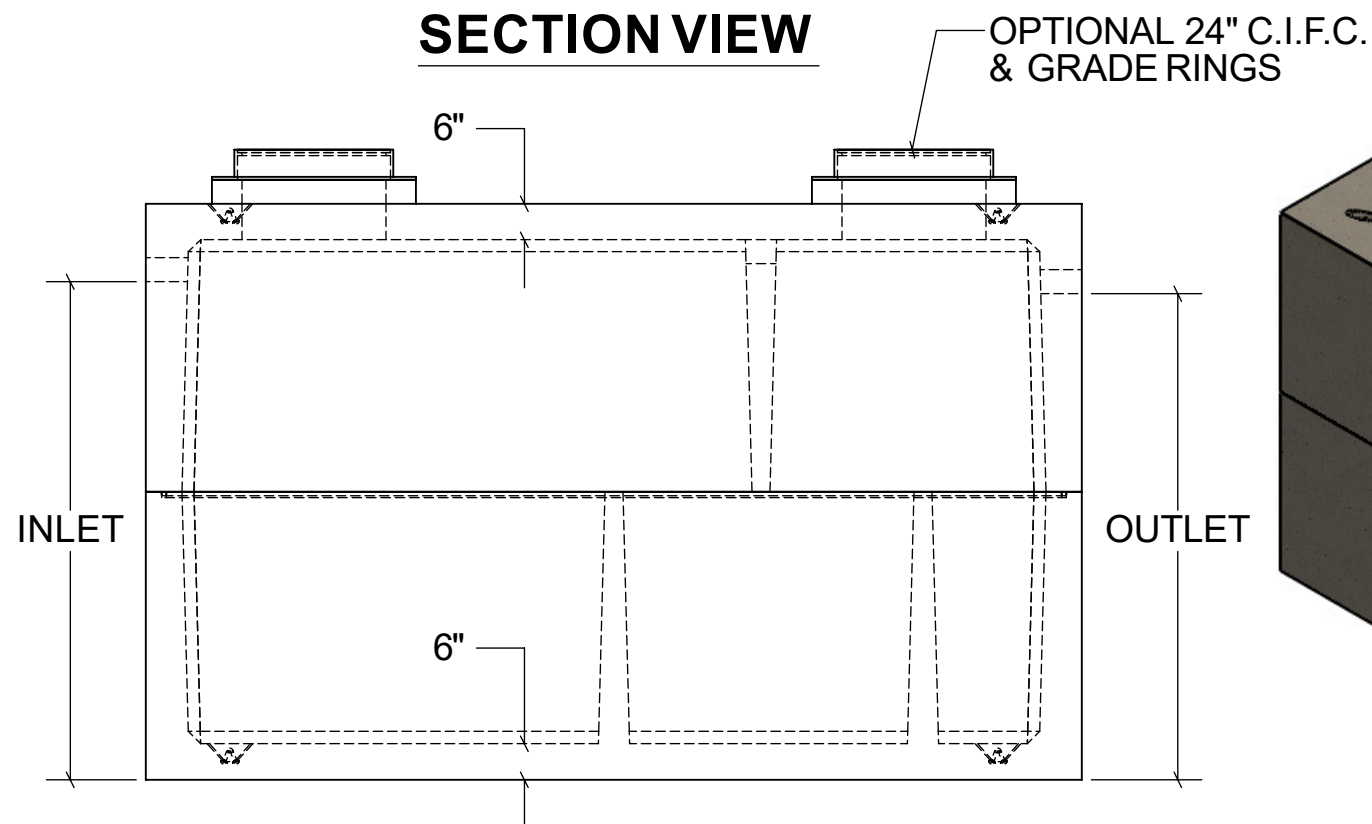

INTERCEPTOR DIMENSIONS

GAL	HEIGHT	INLET	OUTLET	LBS.
2500	79"	66"	64"	33,094
3200	96"	83"	81"	38,182

STRUCTURAL NOTES:

1. ALL CONCRETESHALL BE PLACED IN A SINGLE CONTINUOUS OPERATION (MONOLITHIC POUR).
2. CONCRETESHALL HAVE A MINIMUM 28-DAY COMPRESSIVE STRENGTH OF 4000 PSI CONCRETEAGGREGATE SHALL CONFORM TO ASTM C33.
3. CEMENT SHALL CONFORM TO ASTM C150, TYPE I, II, OR III.
4. ALL STEEL REINFORCEMENTSHALL BE PLACED AS PER ACI 318-89.
5. DESIGN LOAD IS 500 PSF. BASE ON SEVEN(7) FEET OF EARTH COVER.
6. H-20 LOAD RATED

DRAWN:

04/14/23

WEIGHT:

VARIES

SCALE:

VARIES

MATERIAL:

4,000 PSI
CONCRETE

FINISH:
FORM FINISH

DIMENSIONS ARE IN
FEET & INCHES
TOLERANCES: ± 4-IN.

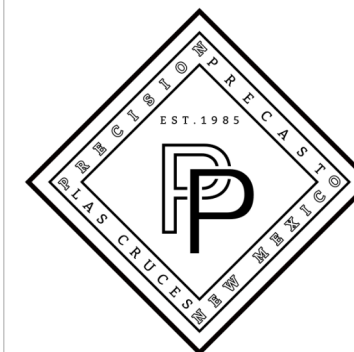

PRECISION PRECAST

575-382-0501

SALES@PRECISIONPRECAST.CO

WWW.PRECISIONPRECAST.CO

PROPRIETARY AND CONFIDENTIAL THE INFORMATION CONTAINED IN THIS DRAWING IS THE SOLE PROPERTY OF LECO INDUSTRIES INC DBA PRECISION PRECAST. ANY REPRODUCTION PART OR AS A WHOLE WITHOUT WRITTEN PERMISSION OF LECO INDUSTRIES, INC DBA PRECISION PRECAST IS PROHIBITED.