

# 4480-WA BOX

**TOP VIEW**

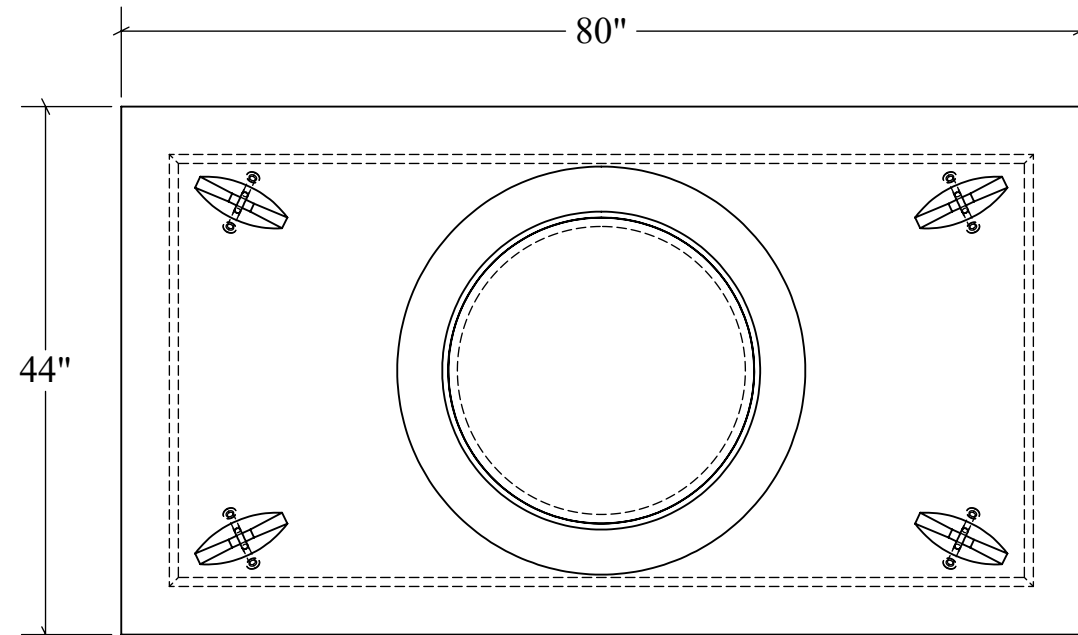

**END VIEW**

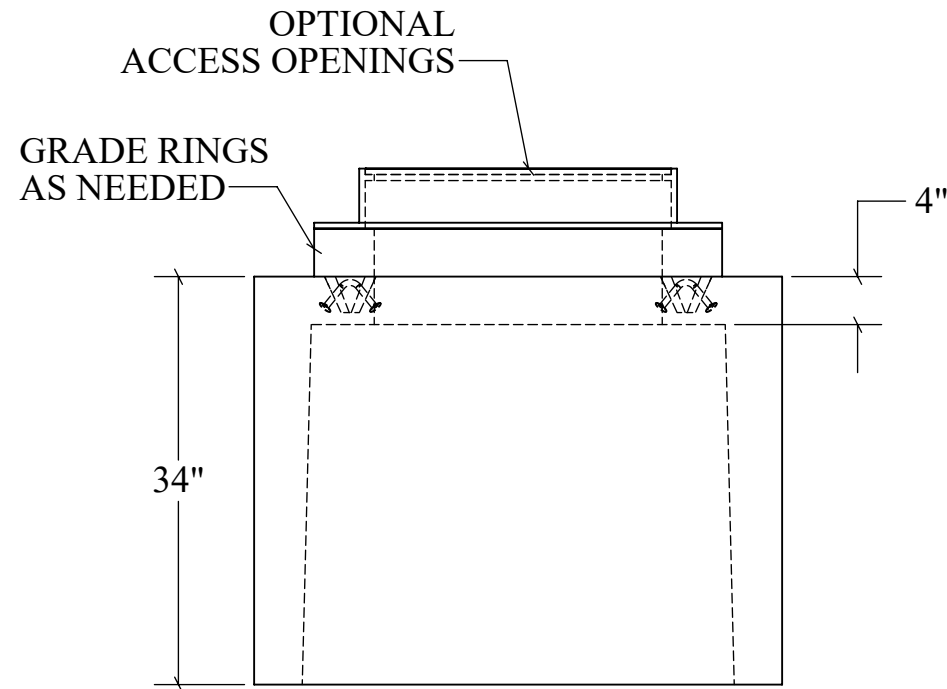

**SECTION VIEW**

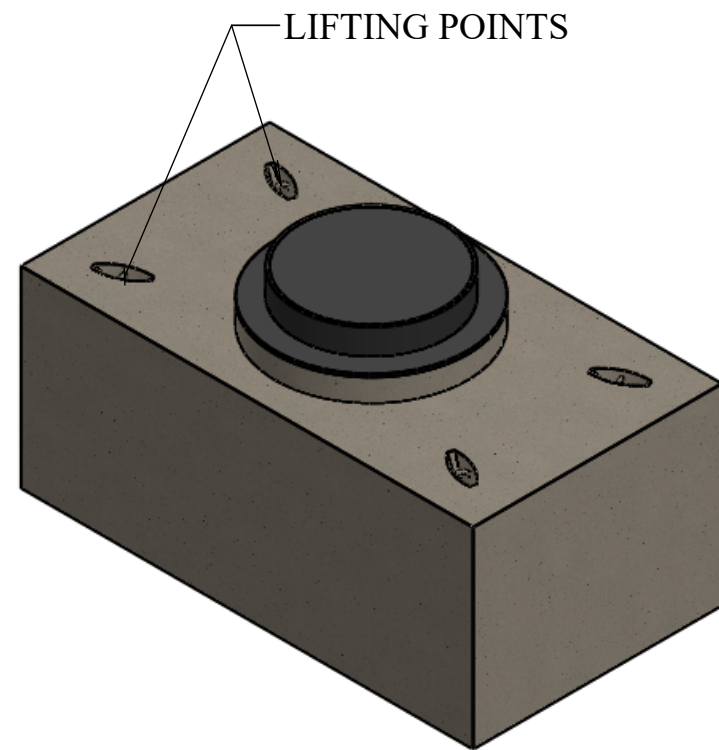
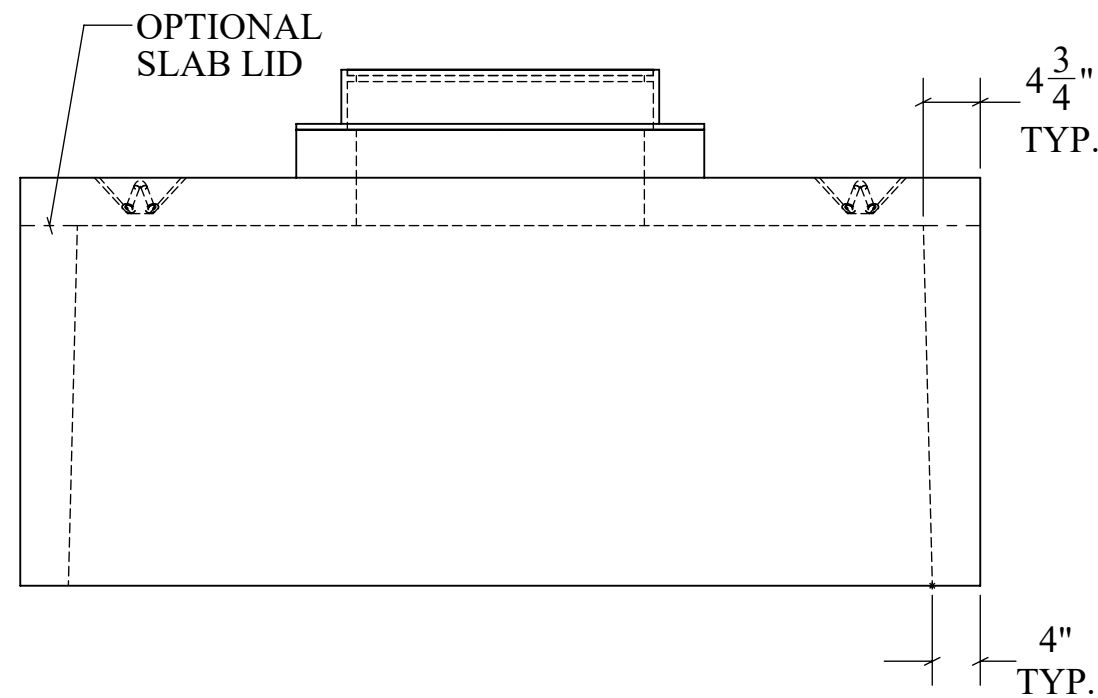

**STRUCTURAL NOTES:**

1. ALL CONCRETE SHALL BE PLACED IN A SINGLE CONTINUOUS OPERATION (MONOLITHIC POUR).
2. CONCRETE SHALL HAVE A MINIMUM 28-DAY COMPRESSIVE STRENGTH OF 4000 PSI CONCRETE AGGREGATE SHALL CONFORM TO ASTM C33.
3. CEMENT SHALL CONFORM TO ASTM C150, TYPE I, II, OR III.
4. DESIGN LOAD IS 300 PSF.

<b>DRAWN:</b> 11/22/22	<b>WEIGHT:</b> 3,686 LBS.	<b>SCALE:</b> VARIES
<b>MATERIAL:</b> 4,000 PSI CONCRETE	<b>FINISH:</b> FORM FINISH	DIMENSIONS ARE IN FEET & INCHES TOLERANCES: ± 4-IN.



**PRECISION PRECAST**  
575-382-0501  
SALES@PRECISIONPRECAST.CO  
WWW.PRECISIONPRECAST.CO

PROPRIETARY AND CONFIDENTIAL THE INFORMATION CONTAINED IN THIS DRAWING IS THE SOLE PROPERTY OF LECO INDUSTRIES INC DBA PRECISION PRECAST. ANY REPRODUCTION PART OR AS A WHOLE WITHOUT WRITTEN PERMISSION OF LECO INDUSTRIES, INC DBA PRECISION PRECAST IS PROHIBITED.