

LARGE DISTRIBUTION BOX

TOP VIEW

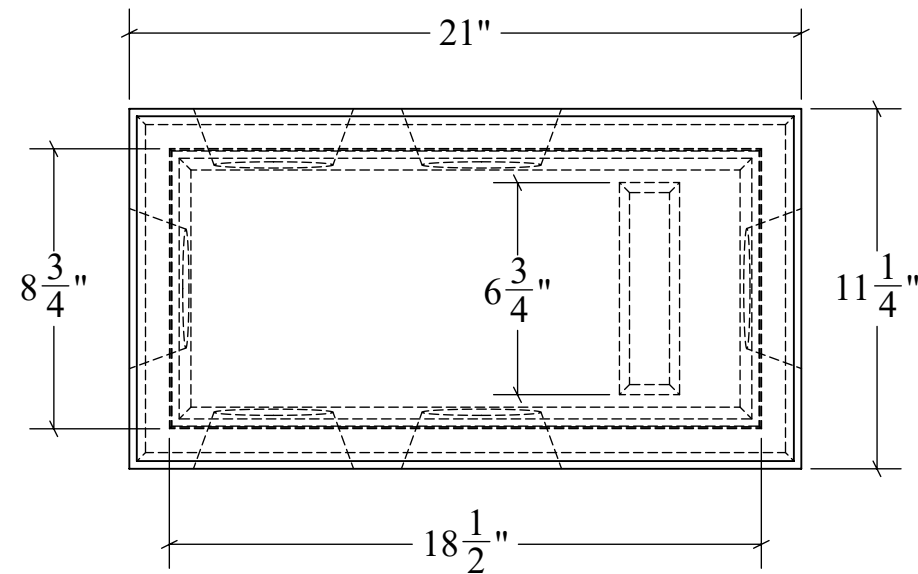

END VIEW

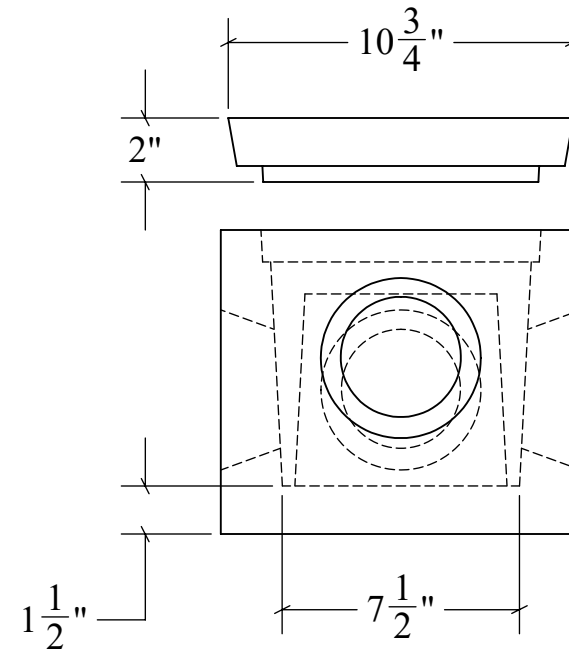

SECTION VIEW

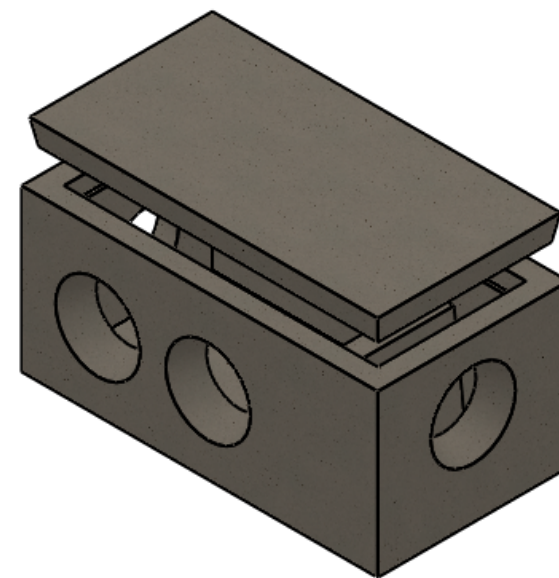
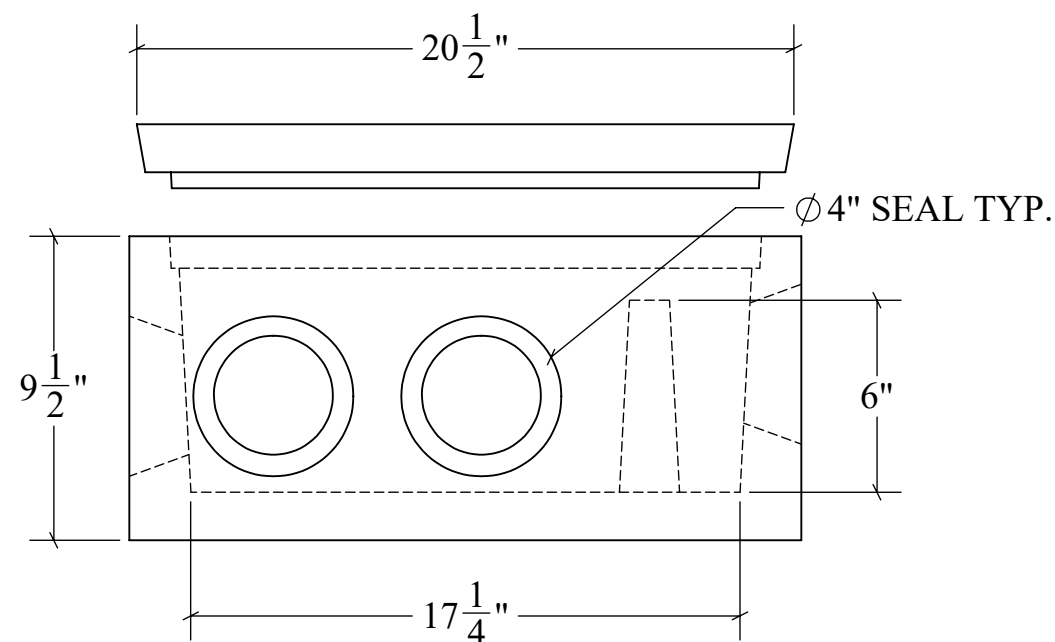

STRUCTURAL NOTES:

1. ALL CONCRETE SHALL BE PLACED IN A SINGLE CONTINUOUS OPERATION (MONOLITHIC POUR).
2. CONCRETE SHALL HAVE A MINIMUM 28-DAY COMPRESSIVE STRENGTH OF 4000 PSI CONCRETE AGGREGATE SHALL CONFORM TO ASTM C33.
3. CEMENT SHALL CONFORM TO ASTM C150, TYPE I, II, OR III.
4. ENGINEERED AND DESIGNED FOR 300 PSF. LOAD.

DRAWN: 06/22/23	WEIGHT: 124 LBS	SCALE: VARIES
MATERIAL: 4,000 PSI CONCRETE	FINISH: FORM FINISH	DIMENSIONS ARE IN FEET & INCHES TOLERANCES: ± 4-IN.



PRECISION PRECAST
575-382-0501
SALES@PRECISIONPRECAST.CO
WWW.PRECISIONPRECAST.CO

PROPRIETARY AND CONFIDENTIAL THE INFORMATION CONTAINED IN THIS DRAWING IS THE SOLE PROPERTY OF LECO INDUSTRIES INC DBA PRECISION PRECAST. ANY REPRODUCTION PART OR AS A WHOLE WITHOUT WRITTEN PERMISSION OF LECO INDUSTRIES, INC DBA PRECISION PRECAST IS PROHIBITED.